



Ultrasonic Atomization Module – MS-03 Technical Datasheet

1. General Description

The MS-03 ultrasonic atomization module features a triple-head design for increased mist output. It is suitable for OEM humidification systems, industrial misting, and applications requiring higher atomization capacity.

2. Technical Specifications

Working Voltage: DC 36V (34–38V)

Working Current: 2.2 – 2.5 A

Frequency: 1.7 MHz

Continuous Output: 1.2 – 1.8 L/H

Droplet Size: 1 – 10 μm

Working Water Temperature: 5 – 45°C

Recommended pH Range: 5 – 8

Optimum Water Level: 30 – 35 mm

Protection Water Level: 10 – 16 mm

Overheat Protection: 55 – 65°C

Lifetime (Clean Water): 3500 – 5000 hours

3. Mechanical Specifications

Housing Material: polished 304 stainless steel housing

Nickel-chrome plated brass compression ring

Atomizing Disc Diameter: $\text{Ø}20 \text{ mm} \times 3$

Dimensions: 171 × 42 × 26 mm

Cable Length: 1500 mm

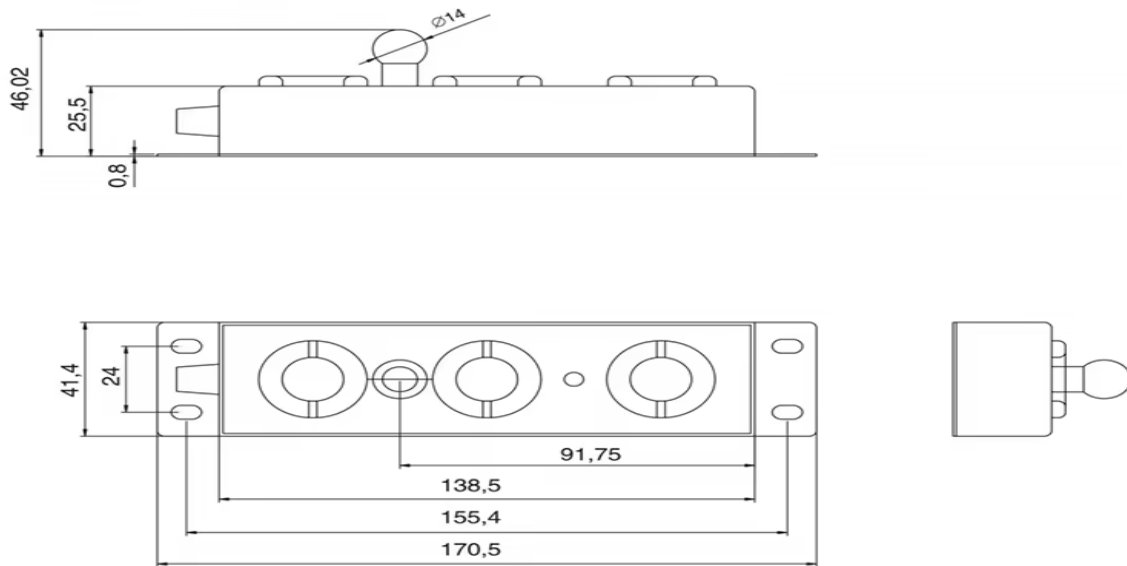

4. Power Supply

Recommended to use AC220V-DC36V / 120W power supply.

5. Features

- High-frequency ultrasonic atomization (1.7 MHz)
- Compact design for OEM integration
- Built-in over-temperature protection
- Water level protection (dry-run prevention)
- Stable constant current operation
- Stainless steel housing for durability

6. Application Areas

- Humidification systems
- HVAC integration
- Industrial misting
- Agricultural / greenhouse use

- OEM equipment integration

7. Important Notes

- Designed primarily for clean water operation
- Recommended pH range: 5–8
- For special liquids (e.g. disinfectants, HOCl solutions), compatibility and lifetime should be verified through testing
- Service life may vary depending on water quality and operating conditions

8. Testing & Evaluation

Samples are available for testing and evaluation upon request.